

Stanley dot matrix character type LCD module



GMD1620BLY

GMD1621BLY

OVERVIEW

Stanley Dot Matrix Module GMD162*BLY (16 characters × 2 line) consists of LC display, C-MOS driver and C-MOS LSI to control.

The module utilizes 5x7 dot matrix characters to provide full alphanumeric capability. All control, refresh and display functions are executed by a dedicated on-board controller. The module is capable of displaying the full 160-character font set.

Data interfacing is via 8-bit bi-directional data bus or a 4-bit one.

By use of simple control commands, data can be selectively written to (or read from) any cursor location and arbitrary fonts can be written to CHARACTER GENERATOR RAM.

It comes in various variations shown below:

- GMD 1 6 2 0 B L Y best viewing angle at 6 o'clock
- GMD 1 6 2 1 B L Y best viewing angle at 12 o'clock

FEATURES

- Control LSI built in. (Control commands : Display clear, Return home, Cursor preset, etc...)
- 5×7 dot matrix with cursor.
- Character Generator ROM built in.
 - 5×7 font ; Alphanumeric-----96characters
 - Japanese-----64characters
- Character Generator RAM(Customer rewritable)
 - 5×7 font ; 8 characters
- LED backlight built in.

compliance with the RoHS directive (issued on February 2003).

PRODUCT SPECIFICATION

Item	Specification	Unit
Number of characters	16character(width) × 2LINE(height)	-
Dimensions	85.0(width) X 36.0(height) X 15.0(thickness)	mm
Effective display area	63.5(width) X 15.8(height)	mm
Characters size	3.20(width) X 5.55(height)	mm
Dot pitch	0.65(width) X 0.70(height)	mm
LCD mode *1 (Positive image)	TN mode Reflective transmissive type	-
Duty ratio	1/16	duty
Back light unit	LED (yellowish green)	-
Interface	4-bit or 8-bit parallel MPU	-
Weight	approx. 40	g

*1 : A property of liquid crystal, as seen in this LCD panel, is that it's color tone changes with variations in ambient temperature.

ABSOLUTE MAXIMUM RATINGS

ENVIRONMENTAL CONDITIONS

Item		Minimum	Maximum	Remarks
Ambient Temperature (= T a)	Operating	0	+50	-
	Storage	-20	+70	-
Humidity		*1		There must be no condensation
Vibration		Conforms to JIS C 60068-2-6 : 1999		Refer to Reliability Testing
Mechanical Shock		Conforms to JIS C 60068-2-27:1995		Refer to Reliability Testing
Corrosive Gas		There must be no corrosive gas		-

*1 : Ta +40 - - - - 90%RH max.

Ta > +40 - - - - - The absolute humidity must be less than 90%RH at Ta = +40°C.

ELECTRICAL CONDITIONS

(Ta=0 ~ +50)

Item	Symbol	Minimum	Maximum	Unit	Remarks
Power Supply for Logic	VDD-VSS	0	7.0	V	
Input Voltage for Logic	V I	VSS	VDD	V	
Operating Voltage for LCD Driving	VDD-VEE	0	13.0	V	

OUTER DIMENSIONS

The tolerance without instruction is $\pm 0.5m$
Frame color : black

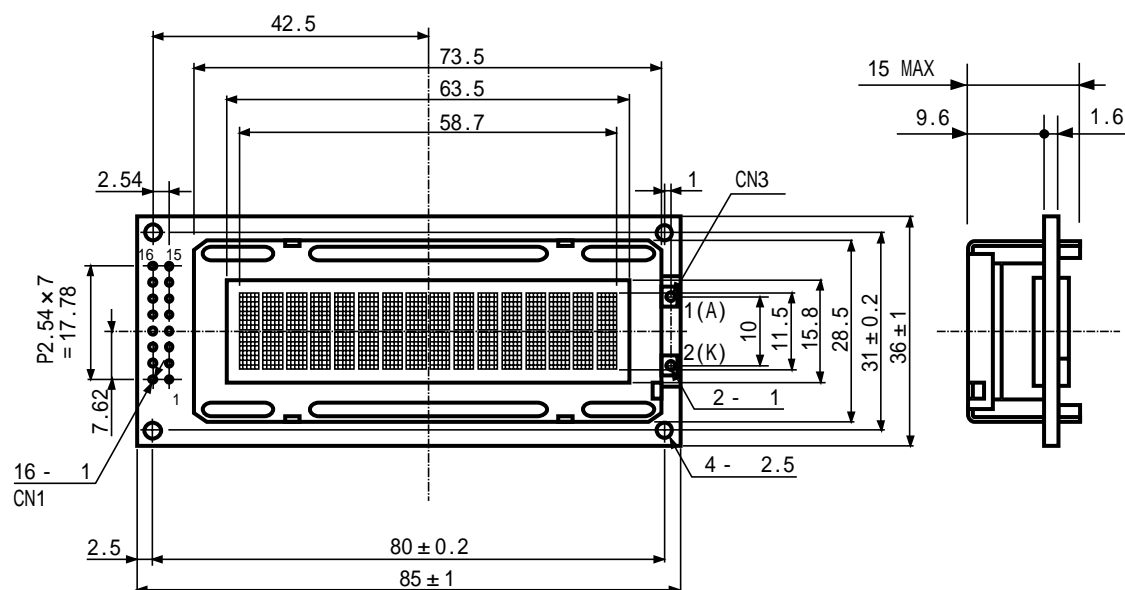

ELECTRICAL SPECIFICATIONS

ELECTRICAL CHARACTERISTICS - LCD OPERATION

(Ta=0 ~ +50 ,duty=1/16)

Item	Symbol	Minimum	Typical	Maximum	Unit	Remarks
Power Supply for Logic	VDD-VSS	4.75	5.0	5.25	V	-
Input "High" Voltage	VIH	2.2	-	VDD	V	-
Input "Low" Voltage	VIL	-0.3	-	0.6	V	-
Output "High" Voltage	VOH	2.4	-	-	V	*1
Output "Low" Voltage	VOL	-	-	0.4	V	*2
Power Supply current	IDD	-	1.0	3.0	mA	*3
Operating Voltage for LCD Driving	VDD-VEE	3.0	-	11.0	V	-

*1 : -IOH=0.205mA

*2 : IOL=1.2mA

*3 : VDD-VSS=5V

BLOCK DIAGRAM

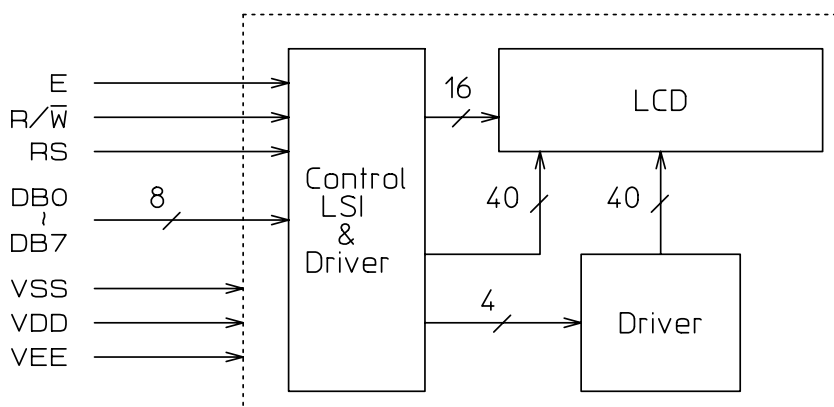

DD RAM ADDRESS

	1	2	3	4	5	12	13	14	15	16
LINE1	00	01	02	03	04		0B	0C	0D	0E	0F
LINE2	40	41	42	43	44		4B	4C	4D	4E	4F

RAM AREA : 00H ~ 27H & 40H ~ 67H (HEX)

POWER SUPPLY

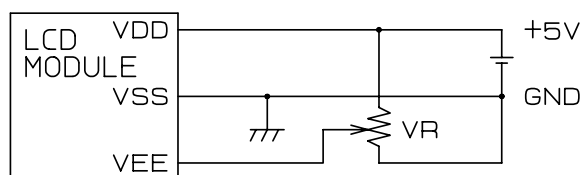

VR : 10~20KΩ

ELECTRICAL CHARACTERISTICS - TERMINAL FUNCTIONS
CON1、CON2

Pin No.	Signal	I/O	Function
1	V S S	-	GND : 0V
2	V D D	-	+5V
3	V E E	-	LCD driving voltage
4	R S	I	Signal to select registers "0" : Instruction register (for write) Busy flag ; address counter (for read) "1" : Data register (for read and write)
5	R / \overline{W}	I	Signal to select read (R) and write (W) "0" : write MPU LCD Module "1" : Read MPU LCD Module
6	E	I	Operation start signal for data read or write.
7	D B 0	I / O	Data bus of lower 4 bits having bi-directional port. Used for data transfer between the MPU and the module. These four are not used during 4bit operation.
8	D B 1		
9	D B 2		
10	D B 3		
11	D B 4	I / O	Data bus of higher 4 bits having bi-directional port. Used for data transfer between the MPU and the module. DB7 can be used as a BUSY flag.
12	D B 5		
13	D B 6		
14	D B 7		
15	(A : LED. +)	-	*1 (CON1 only)
16	(K : LED. -)	-	*1 (CON1 only)

NOTE: In the module, the data can be sent in either 4-bit 2-operation or 8-bit 1-operation so that it can interface to both 4 and 8 bit MPU's.

- 1) When interface data is 4bits long, data is transferred using only 4 buses of DB4 ~ DB7 and DB0 ~ DB3 are not used.
Data transfer between the module and the MPU complete when 4-bit data is transferred twice. Data of the higher 4bits(contents of DB4 ~ DB7 when interface data is 8bits long) is transferred first and lower 4bits (contents of DB0 ~ DB3 when interface data is 8bits long).
- 2) When interface data is 8bits long, data is transferred using 8 data buses of DB0 ~ DB7.

*1: If you connect the "CON3-No.1(A) through-hole (front side PWB)" to " back side PWB through-hole (A), and also connect "CON3-No.2(K) through-hole (front side PWB)" to " back side PWB through-hole (K), in that case CON1-No.15 and No.16 are able to use as terminal of LED backlight.

CON3

Pin No.	Signal	I/O	Function
1	A : LED. +	-	Power supply for LED backlighting +
2	K : LED. -	-	Power supply for LED backlighting -

OPTICAL CHARACTERISTICS

CHARACTERISTICS OF THE LCD PANEL

Item	Symbol	Minimum	Typical	Maximum	Unit	Temp.	Condition
Operating Voltage for LCD Driving (1/16duty)	VDD-VEE	3.4	3.7	-	V	50	$\pm 20^\circ, =0^\circ$
		-	4.3	-	V	25	$\pm 20^\circ, =0^\circ$
		-	4.8	5.0	V	0	$\pm 20^\circ, =0^\circ$
Rise response time	r	-	95	190	ms	25	$\pm 20^\circ, =0^\circ * 1$
Fall response time	d	-	150	300	ms	25	$\pm 20^\circ, =0^\circ * 1$
Contrast ratio	K	3	-	-	-	25	$\pm 20^\circ, =0^\circ * 2$
Range of viewing angle	1- 2	20	-	-	$^\circ$	25	$=0^\circ, K=1.4 * 3$
		± 30	-	-	$^\circ$	25	$\pm 20^\circ, K>1.4 * 3$

*) Measured for LCD panel alone. If heat sources (LEDs, CCFLs, etc) exist in the vicinity, the associated temperature increase must be taken into consideration.

(1) Definition of optical response(*1)

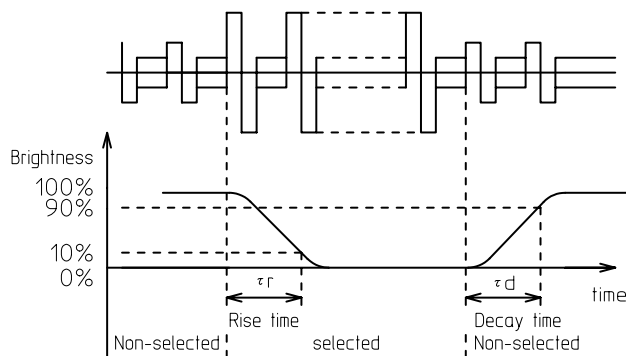

(2) Definition of contrast(*2)

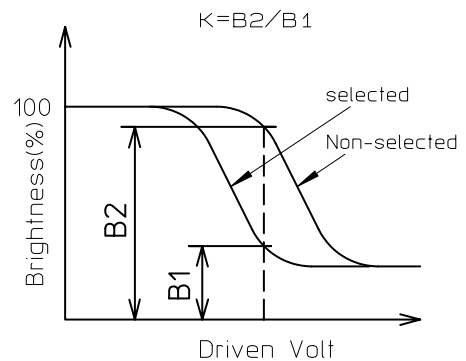

(3) Definition of Viewing angle(*3)

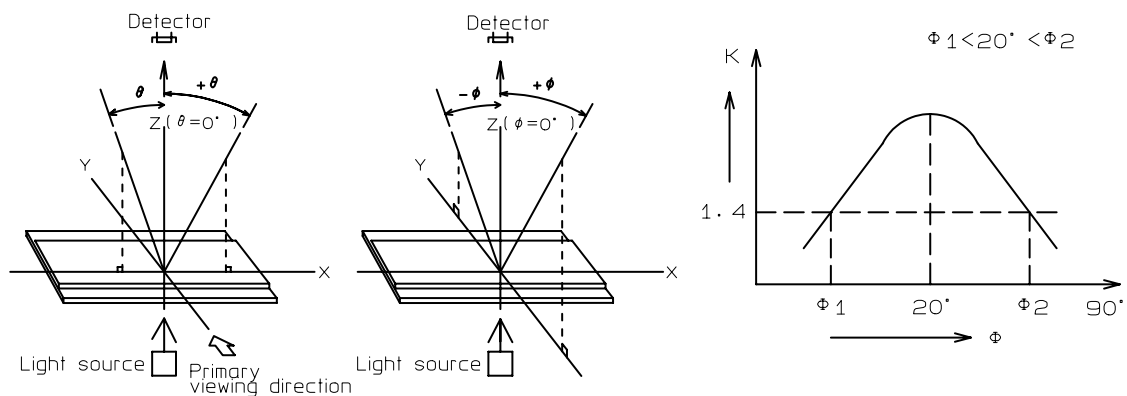

LED BACKLIGHT

ABSOLUTE MAXIMUM RATINGS

(Ta = 25 °C)

Item	Symbol	Rating	Unit
+current(*)	IF	300	mA
-voltage	VR	8	V
power dissipation	PD	1380	mW

ELECTRICAL OPTICAL CHARACTERISTICS

(Ta = 25 °C)

Item	Symbol	Condition	Typical	Maximum	Unit
Forward voltage	VF	IF=120mA	4.2	4.6	V
Reverse current	IR	VR=8V	-	0.2	mA
Luminous intensity	L	IF=120mA	160	-	cd/m ²
Peak wavelength	λp	IF=120mA	570	-	nm

* The current derating for operation above 25 °C is as follows.

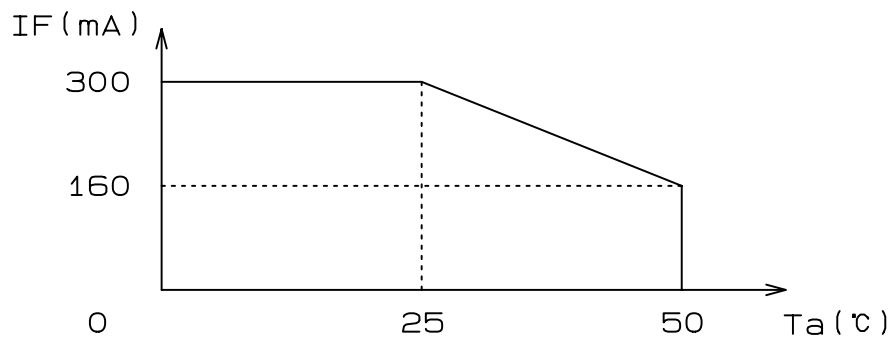

CIRCUIT COMPOSITION

• 2 series x 12 parallel = 24 chips

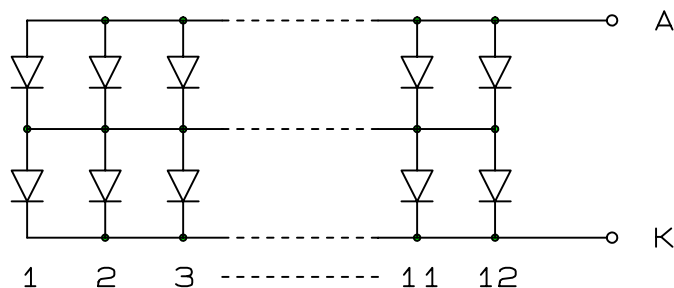

TIMING CHARACTERISTIC

WRITE OPERATION

Item	Symbol	Test condition	Minimum	Typical	Maximum	Unit
Enable cycle time	tCYCE	Refer to the figure	500	-		nsec
Enable pulse width	PWEH	Refer to the figure	230	-	-	nsec
Enable rise time	tEr	Refer to the figure	-	-	20	nsec
Enable fall time	tEf	Refer to the figure	-	-	20	nsec
Set-up time	tAS	Refer to the figure	40	-	-	nsec
Address hold time	tAH	Refer to the figure	10	-	-	nsec
Data set-up time	tDSW	Refer to the figure	80	-	-	nsec
Data hold time	tH	Refer to the figure	10	-	-	nsec

Writing Data (from MPU to Module)

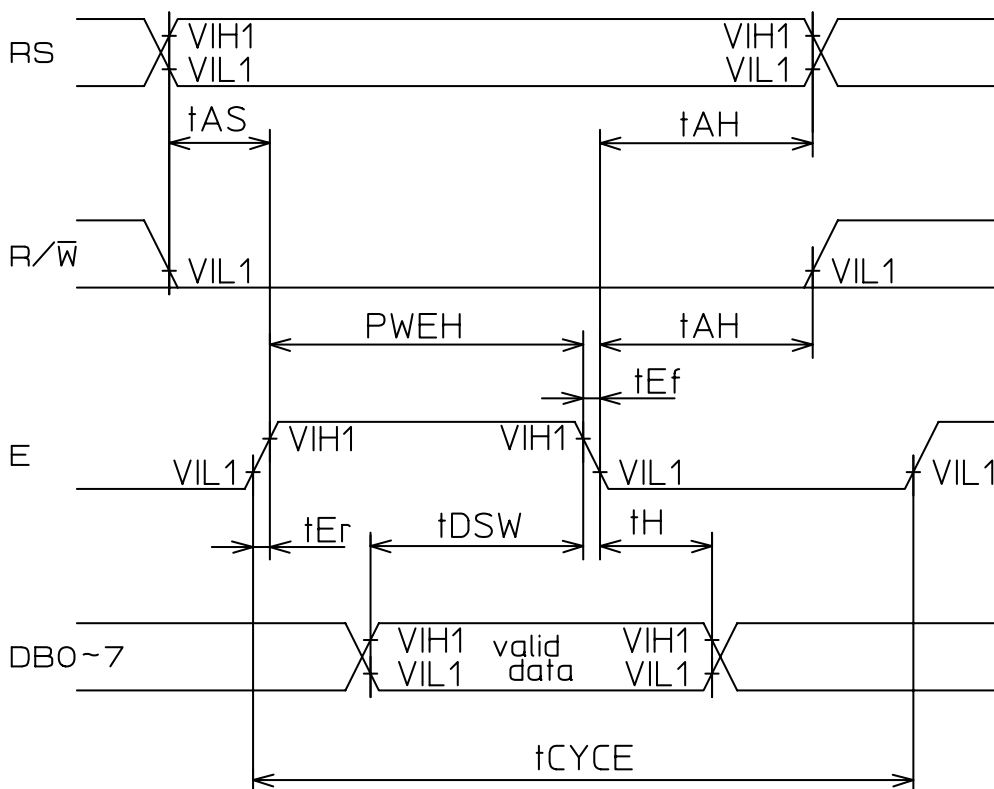

READ OPERATION

Item	Symbol	Test condition	Minimum	Typical	Maximum	Unit
Enable cycle time	tCYCE	Refer to the figure	500	-	-	nsec
Enable pulse width	PWEH	Refer to the figure	230	-	-	nsec
Enable rise time	tEr	Refer to the figure	-	-	20	nsec
Enable fall time	tEf	Refer to the figure	-	-	20	nsec
Set-up time	tAS	Refer to the figure	40	-	-	nsec
Address hold time	tAH	Refer to the figure	10	-	-	nsec
Data delay time	tDDR	Refer to the figure	-	-	120	nsec
Data hold time	tDHR	Refer to the figure	5	-	-	nsec

Reading Data (from Module to MPU)

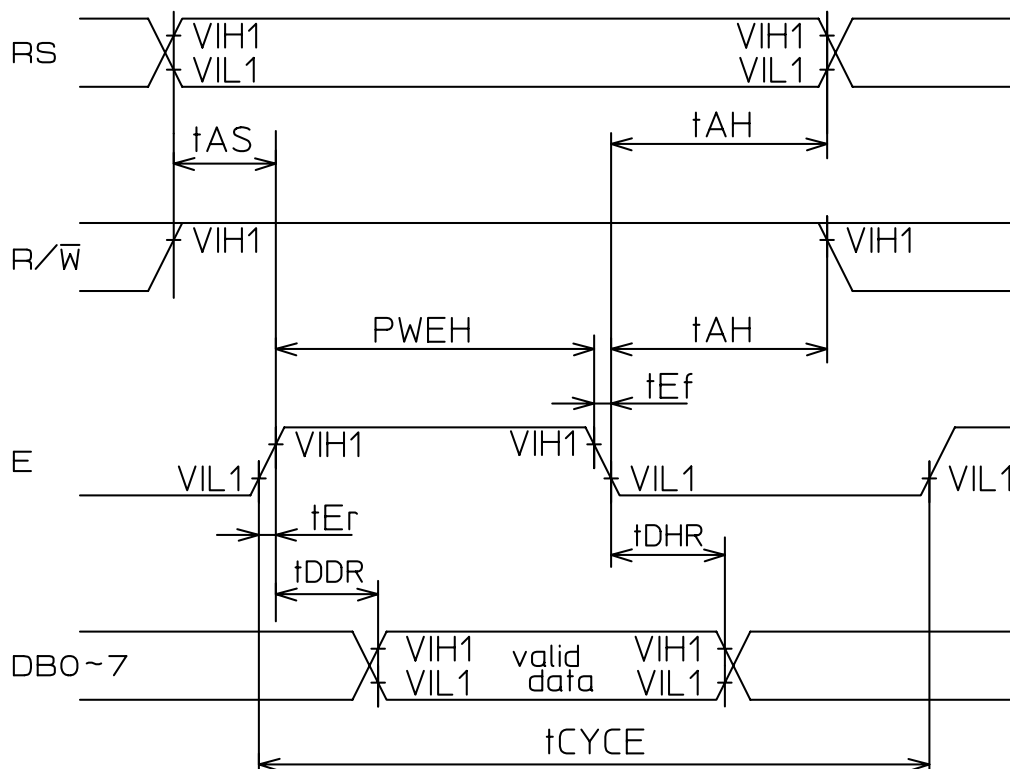

INSTRUCTIONS

Instructions

Instruction	RS	Code										Description	Execution time (max)	
		R/W	DB7	DB6	DB5	DB4	DB3	DB2	DB1	DB0				
Clear Display	0	0	0	0	0	0	0	0	0	0	0	1	Clears entire display and sets DD RAM address 0 in address counter.	1.52ms
Return Home	0	0	0	0	0	0	0	0	0	0	0	*	Sets DD RAM address 0 in address counter. Also returns display being shifted to original position. DD RAM contents remain unchanged.	1.52ms
Entry Mode Set	0	0	0	0	0	0	0	0	0	1	I/D	S	Sets cursor move direction and specifies shift of display. These operations are performed during data write and read.	90µS
Display ON/OFF Control	0	0	0	0	0	0	0	0	1	D	C	B	SETS ON/OFF of entire display(D), cursor ON/OFF(C) and blink of cursor position Character(B).	90µS
Cursor or Display Shift	0	0	0	0	0	0	0	1	S/C	R/L	*	*	Moves cursor and shifts display without changing DD RAM contents.	90µS
Function Set	0	0	0	0	0	0	0	1	DL	N	F	*	Sets interface data length(DL), number of display lines(L) and character font(F).	90µS
Set CG RAM Address	0	0	0	0	1	ACG						Sets CG RAM address. CG RAM data is sent and received after this setting.	90µS	
Set DD RAM Address	0	0	0	1	ADD						Sets DD RAM address. DD RAM data is sent and received after this setting.	90µS		
Read Busy flag & Address	0	1	BF	AC						Reads Busy flag(BF) indicating internal operation is being performed and reads address counter contents.	0µS			
Write Data to CG or DD RAM	1	0	Write Data										Writes data into DD RAM or CG RAM.	90µS
Read Data from CG or DD RAM	1	1	Read Data										Reads data from DD RAM or CG RAM.	90µS
	I/D=1 : Increment , I/D=0 : Decrement S=1 : Accompanies display shift S/C=1 : Display shift , S/C=0 : Cursor move R/L=1 : Shift to the right , R/L=0 : Shift to the left DL=1 : 8bits , DL=0 : 4bits N=1 : 2lines , N=0 : 1line F=1 : 5X10dots , F=0 : 5X7dots BF=1 : Internally operating , BF=0 : Can accept instruction													

RELATIONSHIP BETWEEN CG RAM ADDRESS AND CHARACTER CODE (DD RAM DATA) TO CHARACTER PATTERN (CG RAM DATA)

(For 5X7 dot character patterns)

Character Code (DD RAM Data)	CG RAM Address	Character Pattern (CG RAM Data)																																																
76543210 Upper bits,Lower bits	543 210 Upper bits,Lower bits	76543210 Upper bits,Lower bits																																																
0000*000	000 000 010 011 100 101 110 111	<table border="1"> <tr><td>***</td><td>1</td><td>1</td><td>1</td><td>1</td><td>0</td></tr> <tr><td>↑</td><td>1</td><td>0</td><td>0</td><td>0</td><td>1</td></tr> <tr><td>↓</td><td>1</td><td>0</td><td>0</td><td>0</td><td>1</td></tr> <tr><td></td><td>1</td><td>1</td><td>1</td><td>1</td><td>0</td></tr> <tr><td></td><td>1</td><td>0</td><td>1</td><td>0</td><td>0</td></tr> <tr><td></td><td>1</td><td>0</td><td>0</td><td>1</td><td>0</td></tr> <tr><td></td><td>1</td><td>0</td><td>0</td><td>0</td><td>1</td></tr> <tr><td>***</td><td>0</td><td>0</td><td>0</td><td>0</td><td>0</td></tr> </table> <p>Character pattern example(1) cursor position</p>	***	1	1	1	1	0	↑	1	0	0	0	1	↓	1	0	0	0	1		1	1	1	1	0		1	0	1	0	0		1	0	0	1	0		1	0	0	0	1	***	0	0	0	0	0
***	1	1	1	1	0																																													
↑	1	0	0	0	1																																													
↓	1	0	0	0	1																																													
	1	1	1	1	0																																													
	1	0	1	0	0																																													
	1	0	0	1	0																																													
	1	0	0	0	1																																													
***	0	0	0	0	0																																													
0000*001	001 001 010 011 100 101 110 111	<table border="1"> <tr><td>***</td><td>1</td><td>0</td><td>0</td><td>0</td><td>1</td></tr> <tr><td>↑</td><td>0</td><td>1</td><td>0</td><td>1</td><td>0</td></tr> <tr><td>↓</td><td>1</td><td>1</td><td>1</td><td>1</td><td>1</td></tr> <tr><td></td><td>0</td><td>0</td><td>1</td><td>0</td><td>0</td></tr> <tr><td></td><td>1</td><td>1</td><td>1</td><td>1</td><td>1</td></tr> <tr><td></td><td>0</td><td>0</td><td>1</td><td>0</td><td>0</td></tr> <tr><td></td><td>0</td><td>0</td><td>1</td><td>0</td><td>0</td></tr> <tr><td>***</td><td>0</td><td>0</td><td>0</td><td>0</td><td>0</td></tr> </table> <p>Character pattern example(2) cursor position</p>	***	1	0	0	0	1	↑	0	1	0	1	0	↓	1	1	1	1	1		0	0	1	0	0		1	1	1	1	1		0	0	1	0	0		0	0	1	0	0	***	0	0	0	0	0
***	1	0	0	0	1																																													
↑	0	1	0	1	0																																													
↓	1	1	1	1	1																																													
	0	0	1	0	0																																													
	1	1	1	1	1																																													
	0	0	1	0	0																																													
	0	0	1	0	0																																													
***	0	0	0	0	0																																													
0000*111	111 100 101 110 111	<table border="1"> <tr><td>***</td><td></td><td></td><td></td><td></td><td></td></tr> <tr><td>↑</td><td></td><td></td><td></td><td></td><td></td></tr> <tr><td>↓</td><td></td><td></td><td></td><td></td><td></td></tr> <tr><td></td><td></td><td></td><td></td><td></td><td></td></tr> <tr><td></td><td></td><td></td><td></td><td></td><td></td></tr> <tr><td></td><td></td><td></td><td></td><td></td><td></td></tr> <tr><td></td><td></td><td></td><td></td><td></td><td></td></tr> <tr><td>***</td><td></td><td></td><td></td><td></td><td></td></tr> </table>	***						↑						↓																														***					

↑																																																		
↓																																																		

* : Don't Care

NOTES

- Character code bits 0-2 correspond to CGRAM address bits 3-5 (3bits: 8 characters).
- CGRAM address bits 0-2 designate character pattern line position. The 8th line is the cursor position and display is performed in logical OR the cursor. Maintain the 8th line data, corresponding to the cursor display position in the "0", state for cursor display. When the 8th line data is "1", bit 1 lights up regardless of cursor existence.
- Character pattern row positions correspond to CGRAM data bits 0-4, as shown in the figure (bit 4 being at the left end). Since CGRAM data bits 5-7 are not used for display, these can be used for the general data RAM.
- As shown in the table above, the CGRAM character patterns are selected when character code bit 4-7 are all "0". However, since character code bit 3 is an ineffective bit, the "R" display in the character pattern example, is selected by character code "00" (hexadecimal) or "08"(hexadecimal).
- "1" for CGRAM data corresponds to selection for display and "0" for no selection.

CORRESPONDENCE BETWEEN CHARACTER CODES AND CHARACTER PATTERN

Higher 4bit Lower 4bit	0000	0010	0011	0100	0101	0110	0111	1010	1011	1100	1101	1110	1111
XXXX0000	CG RAM (1)												
XXXX0001	(2)												
XXXX0010	(3)												
XXXX0011	(4)												
XXXX0100	(5)												
XXXX0101	(6)												
XXXX0110	(7)												
XXXX0111	(8)												
XXXX1000	(1)												
XXXX1001	(2)												
XXXX1010	(3)												
XXXX1011	(4)												
XXXX1100	(5)												
XXXX1101	(6)												
XXXX1110	(7)												
XXXX1111	(8)												

RESET FUNCTION

The module automatically performs initialization (reset) when power is turned on. (using internal reset circuit) The following instructions are executed in initialization. The BUSY FLAG is kept in the busy state (BF=1) until initialization ends. The time is 15 ms.

- 1) Clear display
- 2) Function set
DL=1: 8 bits long interface data
N =0: 1-line display
F =0: 5x7 dot character font
- 3) Display ON/OFF control
D =0: Display OFF
C =0: Cursor OFF
B =0: Blink OFF
- 4) Entry mode set
I/D=1: +1 (increment)
S =0: No shift
- 5) DDRAM selected

Because initialization may not be performed completely depending on the rise time of the power supply when it is turned on, pay attention to the following time relationship.

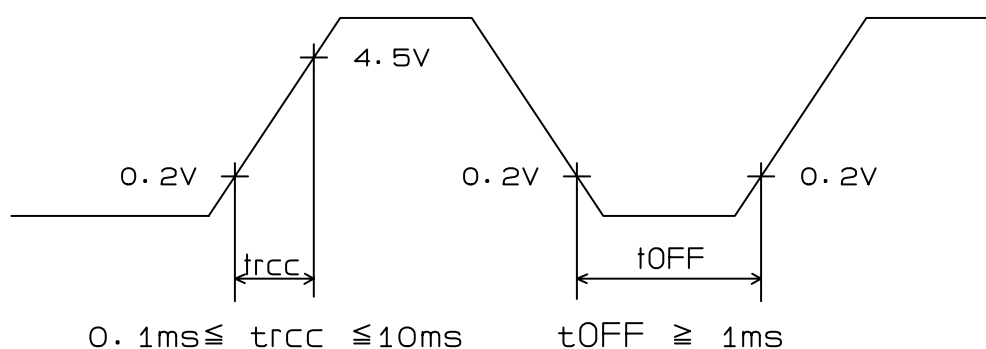

t_{OFF} stipulates the time of power OFF for power supply instantaneous dip or when power supply repeats ON and OFF.

NOTES

When the above power supply condition is not satisfied, the internal reset circuit does not operate normally.

INITIALIZING BY INSTRUCTION

If the power supply conditions for correctly operating the internal reset circuit are not met, initialization by instructions becomes necessary.

8-BIT INITIALIZATION

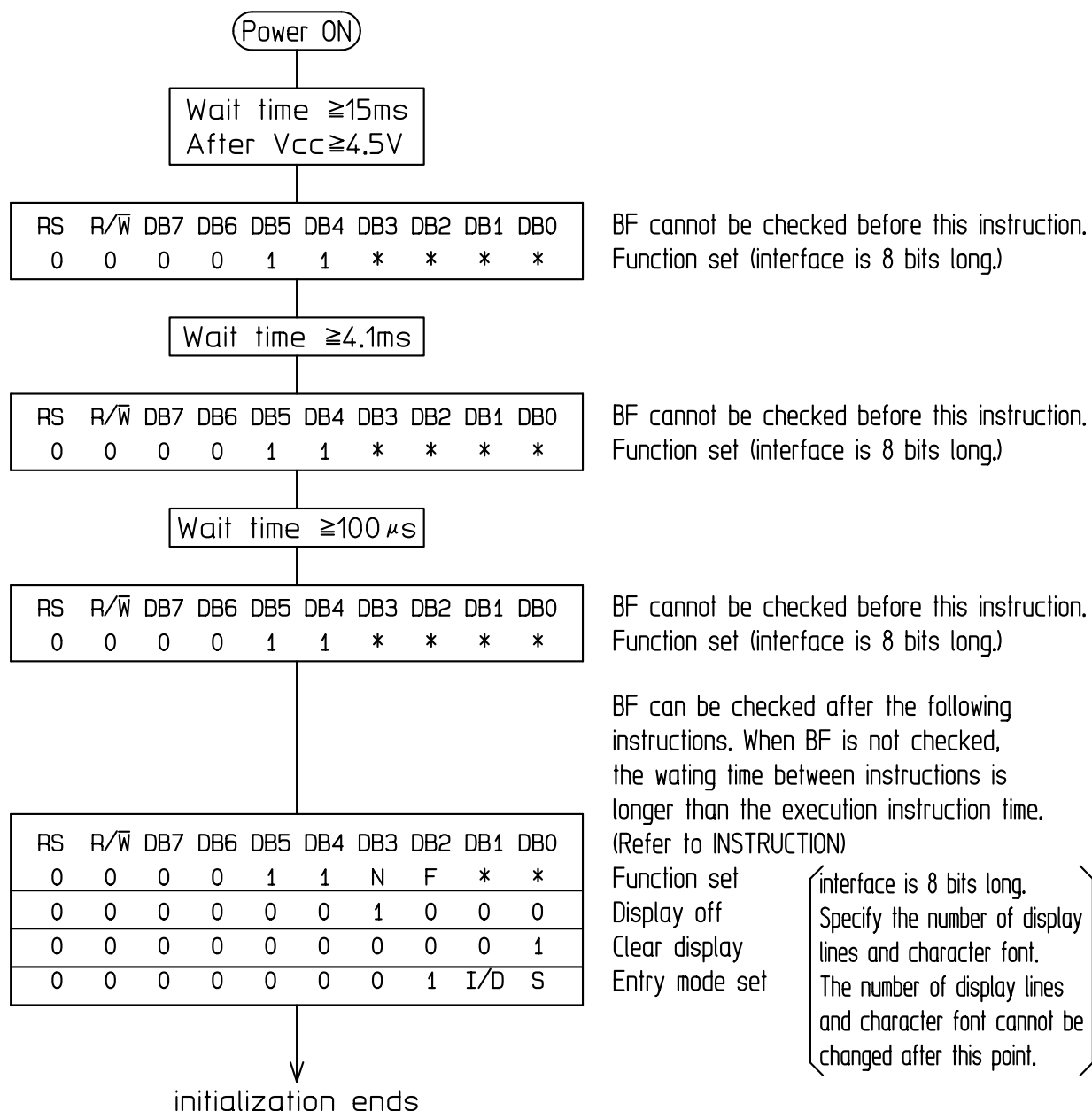

4-BIT INITIATION

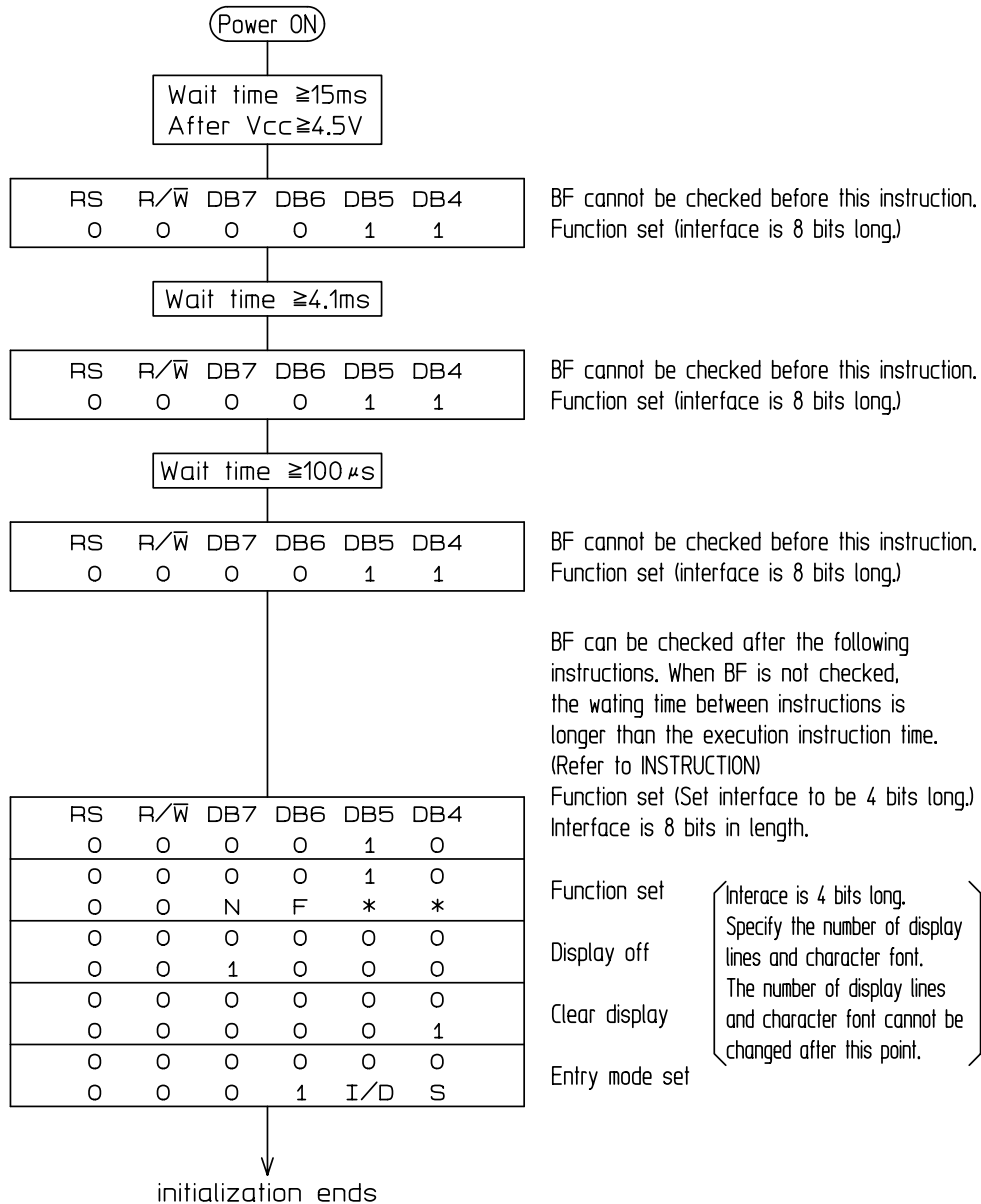



Instruction of use

Handling precautions

- Extra care must be exercised to protect it from a mechanical impact or shock. Because the LC panel is made of glass, it may be broken if a strong impact is applied to it.
- The polarizer on the surface of the display gets scratched easily. Do not press such as tweezers, tools or other hard materials against the polarizer, and do not scratch the polarizer with them.
- The polarizer may be damaged if it comes into contact with an organic solvent. If the display surface becomes stained, remove the stain by applying cellophane tape, or wipe the display surface lightly using a soft cloth, such as an absorbent cotton cloth with diluted neutral detergent.
- If water drops adhere to the display surface for a long time, they cause discoloring or will become unremovable stains. If these are found on the display surface, wipe them off immediately.
- The liquid (liquid crystal) inside the liquid crystal panel is a harmful substance. If the liquid crystal panel is broken, do not put the spilled liquid crystal in the mouth, and if adhere to the skin or clothes, apply soap and wash is away.
- To prevent damage of LSI and LED by static electricity, do electrostatic measures such as earth bands when you remove the protection film from LCD panel.
- This product is designed for use in air-conditioned, no vibrated and no impacted indoors. And this product has to be used above condition.
- Films such as heat seal and TCP(Tape Carrier Package) are used in the LCD module. When using the LCD module, pay extra attention to avoid damaging the films. If film is damaged, it causes malfunction display.
- The following LCD modules uses rubber connector (conducting elastomer). Do not warp or twist at handling.

Pertinent products:

GMD1620B, GMD1621B, GMD1620BLY, GMD1621BLY, GMD1620BSLY, GMD1621BSLY,
GMD2020B, GMD2021B, GMD2020BLY, GMD2021BLY, GMD2020BSLY, GMD2021BSLY,
GMF32024ABTW, GMF32024BSLY, GMF64020ABTW

Storage precautions

- Do not storage or use the LCD module at high temperature and high humidity. If stored or used at high temperature and humidity, air bubbles may occur or the polarizer may peel off from the surface. When storing the LCD module, put it in an electrically-conductive plastic bag or delivered package, and store it at low temperature (+5 to +30), at low humidity (RH= 30 to 70%) and not in direct sunlight or fluorescent light.
- Use the pure water or distilled water when you use the humidifier to prevent dryness. Do not use tap water because it includes chlorine and it may damage module.
- Do not store at high temperature such as in direct sunlight or near heating facility.
- Do not store at rapid temperature change's place such as in direct sunlight or strong lightings, because it causes condensation. Pleas store it in constant temperature place.
- Store at no dust, no corrosive gas (exhausting, smoke, NOx and SOx included in chemical, and so on) and no salinity condition.
- Do not expose to radiation, static electricity and strong magnetic field.

Operating precautions

- Do not connect it to or disconnect it from the main system when the LCD module is powered on.
- If the LCD module is stored at temperatures below or above the specified storage temperature limits, it may malfunction and it may not be restored even after the temperature is adjusted to the specified storage temperature.
- Optical characteristics (viewing angle and contrast ratio) are depended on LCD driving voltage. Please adjust it to achieve optimum contrast ratio in each module.

Driving voltage (VDD-Vo):

GMF32024ABTW, GMF32024BSLY, GMF32024HBTW,
GMF32024HFTW, GMF64020ABTW

Driving voltage (VEE-VSS):

GMF32024JBTW, GMF32124JBTW, GMF32024JFTW,
GMF32124JFTW, GMF32024KFTW, GMF32124KFTW

- Do not use the module in dewy, a lot of moisture, or other solutions.
If even slight condensation occurs or splashes solutions at the terminals of LCD panel, electrochemical reactions will occur on the terminals, and terminal may be damaged and disconnected. Please note to prevent rapid temperature changes, because it may causes condensation.
- Do not touch the connector terminals, PWB, and electronic components when the LCD module is operating. Especially CCFL connectors are applied high voltage, and there is a danger of the electric shock.
Touching them may also cause malfunction of LCD module.
- Each product is designed to operate at specified driving duty ratio. If it is operated at a different duty ratio, it may be malfunction.

1/200 duty drive: GMF64020ABTW

1/240 duty drive: GMF32024ABTW, GMF32024BSLY, GMF32024HBTW, GMF32024HFTW,
GMF32024JBTW, GMF32124JBTW, GMF32024JFTW, GMF32124JFTW,
GMF32024KFTW, GMF32124KFTW

- When LC panel is applied the DC voltage, its lifetime is shortened rapidly by electrochemical reaction. When using the GMF series LCD module, keep following power supply sequence to prevent the DC voltage being applied to the panel and to prevent the latch-up of CMOS-LSI in the module.

If the LC driving voltage or various signals are input before the logic power supply is stabilized, the internal LSI may be damaged due to floating or latch-up phenomena.

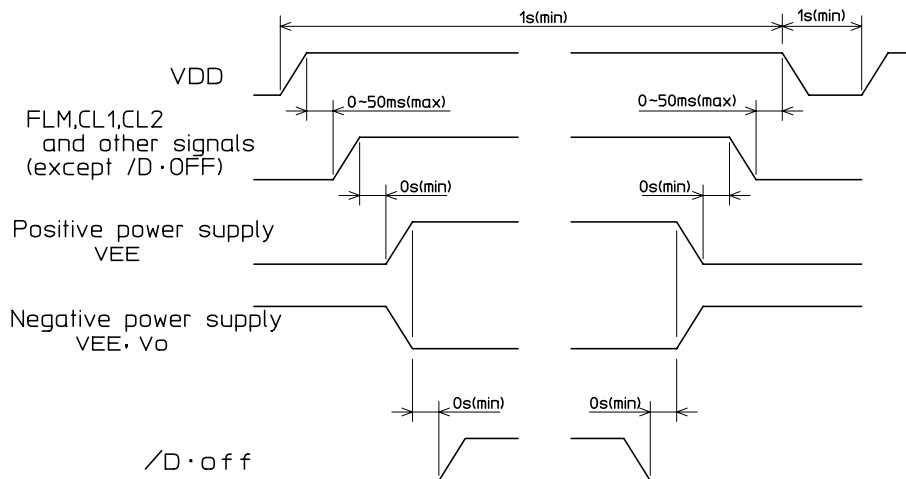

Installation precautions

- Do not remodel or disassemble the LCD module. If it malfunctions after being remodeled or disassembled and assembled again, Stanley electric is not liable for such malfunctions.
- Workers have to be grounded by such as earth-bands and put antistatic cloths, to prevent electrifying, because CMOS-LSI are used in the module.
- The LCD module is designed to be installed using mounting holes at the four corners. Make sure that the display surface is completely flat after it is installed in position. When mounting and installing it, do not warp or twist it and do not apply stress to it. If it is warped or twisted or stress is applied to it, discoloring may occur, or the LCD may be damaged.
- To protect the polarizer and the LC panel, install a protective panel, such as a clear acrylic plate. And keep a clearance between the protective panel and the module to prevent stress to the module.
- If dirt or dust enters the inside of the LCD module, the display quality may be adversely affected. If the LCD module is used in a dusty place, take precautionary measures to protect it from dust.
- The metal frame or plastic frame of module is not visual inspection subject. It might have some scratches. Please design to cover or conceal the metal frame or plastic frame when it is installed.
- Lighting source such as CCFL/LED backlight in the module, is heated. To note the heat radiation and do not exceed the ambient temperature in the specification when it is operating.
- Do not arrange the parts which is damaged by light, because a LCD module has some light leaking at the back and side.
- GMF32024HBTW and GMF32024HFTW are available to exchange its CCFL. When you exchange the CCFL, please note handling and prevent CCFL cracking and impact to the module. And CCFL have to be exchanged after turn off the power supply, because it is applied high voltage.
GMF32024ABTW FG terminal or PWB's installation hole has to be grounded to prevent the LSI malfunction or damage by static electricity.

Precautions for safety

- There might be some burr at the edge of the metal frame, be care of the injury.
- When designing of the installation, the cable for the connector must not come in contact with the metal part such as a metal frame.
- There is no protection circuit for short-circuit trouble in the module. For safety measures, please built in fuse or shut-down circuit in system power supply.

**SPECIAL NOTICE TO CUSTOMERS USING THE PRODUCTS AND TECHNICAL
INFORMATION SHOWN IN THIS DATA SHEET**

- 1) The technical information shown in these data sheets is limited to the typical characteristics and circuit examples of the referenced products. It does not constitute the warranting of industrial property or the granting of any license.
- 2) For the purpose of product improvement, the specifications, characteristics, and technical data described in these data sheets are subject to change without prior notice. Therefore, it is recommended that the most updated specifications be used in your design.
- 3) When using the products described in these data sheets, please adhere to the maximum ratings for operating voltage, heat dissipation characteristics, and other precautions for use which are described in the most updated specifications. We are not responsible for any damage which may occur if these specifications are exceeded.
- 4) The products described in the data sheets were produced to be used with standard electronic equipment (OA machines, correspondence equipment, AV apparatus, household appliances and measuring equipment). For uses other than those described above, High reliability and safety are required. for customers planning to use these products for applications that could result in failure or malfunction liable to have a direct adverse effect on human life or body (aircraft, spacecraft, transport machinery, medical apparatus, atomic control equipment etc...), please contact Stanley beforehand.
- 5) In order to export the products or technologies described in this data sheet which are under the "Foreign Exchange and Foreign Trade Control Law", it is necessary to first obtain an export permit from the Japanese government.
- 6) No part of this data sheet may be reprinted or reproduced without the prior written permission form Stanley Electric Co., Ltd.
- 7) If you have any questions concerning the products or services offered in this data sheet, please contact us at your convenience.
- 8) The latest edition of these data sheets can be obtained from the following addresses.

Home page address <http://www.stanley-components.com>